



TransTech Systems, Inc.
Toll Free: 1-888-VIDEO-ID

Phone: 503-682-3292
Fax: 503-682-0166

Wilsonville, OR 97070
www.ttsys.com

This access control unit uses wireless communication. It is recommended that a Net2Air site surveyor is used to determine the best position for the Net2Air bridge and Nano control units.

This unit requires a Net2Air bridge (USB or Ethernet) to communicate with the controlling PC running Net2 v4.14 or later software.

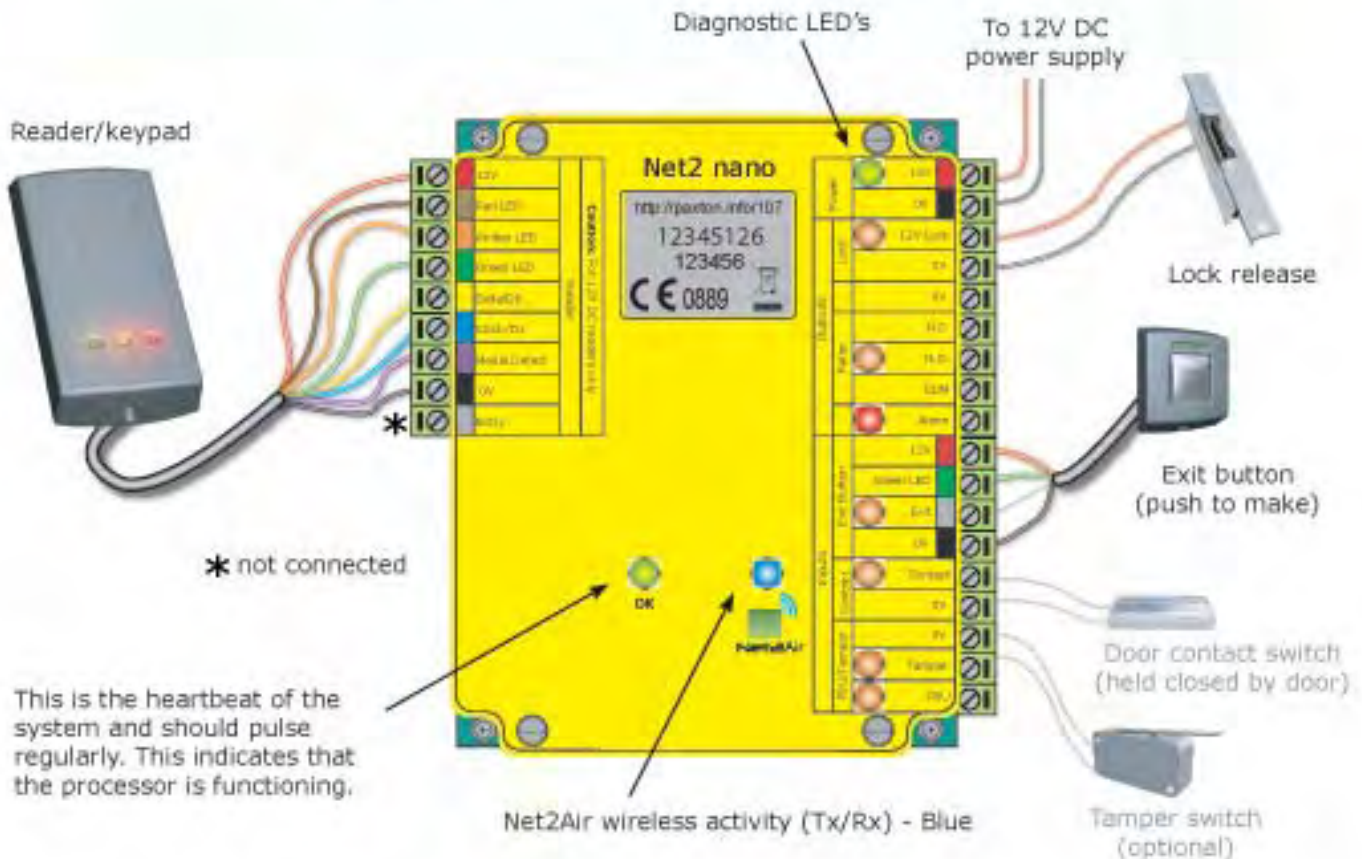

A new unit requires approximately 30 seconds after initial power up to self configure. During this time the OK LED will not be flashing.

The unit will not operate until this operation has completed.

LED indications

12V	(Green)	- Power LED
Lock	(Orange)	- The 12V lock output is energised
Relay	(Orange)	- The relay is energised - (NO/COM contacts are closed)
Alarm	(Red)	- 12V Alarm output is active
Exit	(Orange)	- The exit button contacts are closed
Contact	(Orange)	- The door contacts are closed
Tamper	(Orange)	- The tamper contacts are closed
PSU	(Orange)	- The PSU contacts are closed
Net2Air	(Blue)	- Net2Air interface Tx/Rx activity
OK	(Green flash)	- The internal software is running

Net2Air wireless communication

Net2Air wireless control units are fully compatible with the hard wired Net2 range but there are several important differences that need to be understood before installing wireless equipment. The most important of these is the location of the control units and their bridge components.

These principles are therefore explained first before we move on to the control unit itself.

The access control unit connects to the Net2 software running on the PC using Paxton Access' Net2Air proprietary wireless technology. A Net2Air bridge enables communication from the Net2 software to the Paxton Access nano family of products.

Radio signals do not always behave as you might expect. For example, a mobile phone that displays a full signal on one part of the site will lose signal completely only a few metres away. These problems can be addressed by using the Net2 site surveyor kit. (690-200)

See also: [AN1095 - Net2 nano - How does it work? < http://paxton.info/974 >](http://paxton.info/974)
[AN1096 - How to plan a Net2 nano installation < http://paxton.info/975 >](http://paxton.info/975)
[Ins-30096 - Net2Air site surveyor < http://paxton.info/1015 >](http://paxton.info/1015)

A Net2 nano ACU or a Hands free interface cannot be installed in a Metal cabinet as this would block the RF signal used for the Net2Air wireless technology.

Net2 nano / server operation

Data transfer with wireless technology requires far more control and error checking than with a hard wired data line connection. Net2 classic runs with a server that originates and controls all the communications on the data line. This would not be efficient in a wireless environment.

We therefore give the Nano controller the active role. Each Nano is always active and transmits data bursts (including a regular Heartbeat) every few seconds. The Net2 server then acts upon these requests for service.

The PC requires at least one Net2Air bridge to communicate with a Nano. This can be a local Net2Air USB bridge (only one per system) and/or multiple Net2Air Ethernet bridge units connected to the PC via a TCP/IP connection.

There is NO Net2 nano detection function. It is recognised that there could be security issues if the wireless units were detectable from outside the site. During installation, a nano unit makes a permanent one-to-one link with a Net2Air bridge and is then enrolled into the Net2 database.

An entry is then made on the Doors screen and a special icon is used to denote the wireless connection. 



The reader's default indication has all the LED's on. Access granted is denoted with a single flashing Green LED, Access Denied is a single flashing Red LED.

PC Installation

The current specification for compatible PC hardware, network and operating systems is available on our website at the following link: <http://paxton.info/720>

Control unit installation

Wire the components to the Access Control Unit (ACU) as shown on the first page. This will include:

- Reader/Keypad
- Electric Lock
- Power supply
- Any other optional components



TransTech Systems
PO Box 2357 Wilsonville, OR 97070
Phone: 888.843.3643 Fax 503.682.0166
Email sales@ttsys.com www.ttsys.com

Press the exit button or in the absence of an exit button, short the 0V and exit terminals together. The Relay LED will come on and the lock should release.

Software installation

Once all the ACU's have been tested and the Nano powered up, the Net2Air bridges need to be configured.

A USB Net2Air bridge will be registered by the Net2 software automatically. This displays in the Net2 Server Configuration Utility/Net2Air bridge as a fixed USB entry. Click OK to store this data.

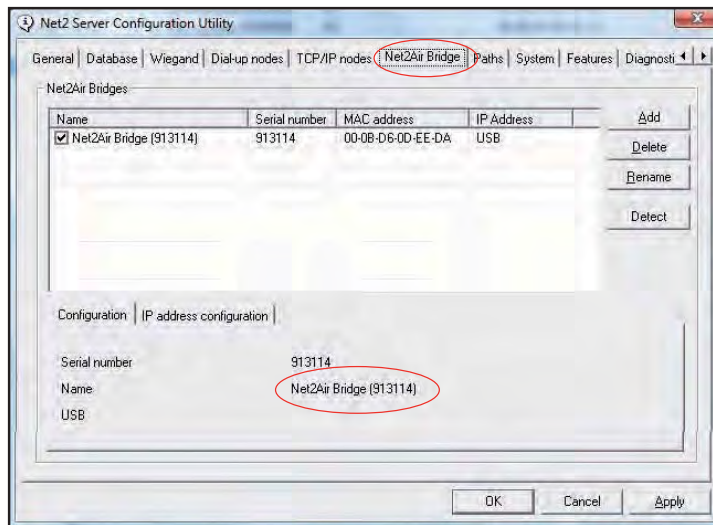

To register an Ethernet Net2Air bridge, click on Detect and setup the IP addresses as required. See also: [Ins-30085 - Net2Air Ethernet bridge < http://paxton.info/920 >](http://paxton.info/920)

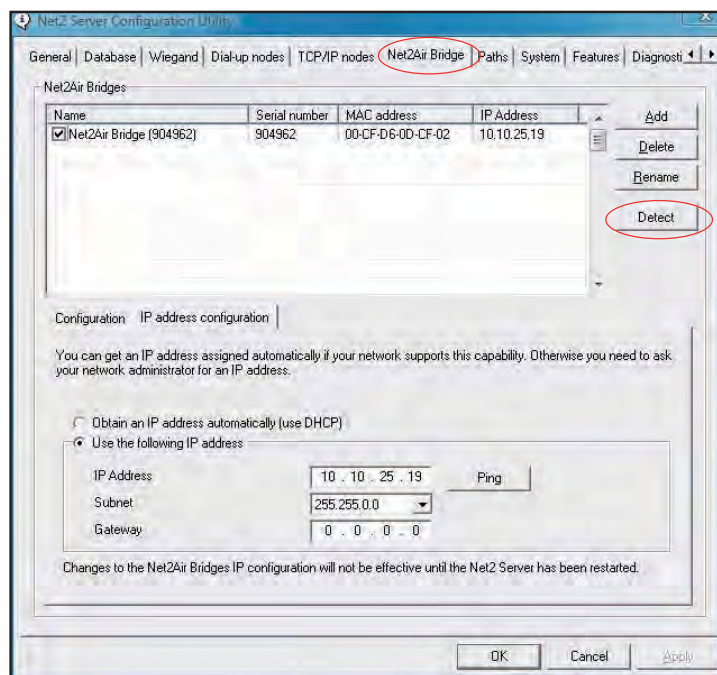

Radio frequency

If you are experiencing problems with the range or reliability this may be due to poor nano / bridge positioning.

The unit is set to channel 11 (2.405 GHz) as this frequency is normally clear of other device transmissions. Technical Support can advise if you are concerned about interference from adjacent radio based (WiFi) equipment.



TransTech Systems
PO Box 2357 Wilsonville, OR 97070
Phone: 888.843.3643 Fax 503.682.0166
Email sales@ttsys.com www.ttsys.com

Enrolling a Net2 nano

A Nano must first bind to a Net2Air bridge before it will enroll itself onto the Net2 system. The term 'bind' is used to denote the fixed relationship between a Nano and its bridge.

Create a user record in the database and assign a Net2 token to the user. If you are not using PROXIMITY tokens you should still create the user record and assign a token number (Not a PIN) of your choice. These records can be deleted after the installation is complete.

Connect a PROXIMITY reader to the Nano and then present the same user token previously assigned. (If you are enrolling a Keypad only unit, enter the token number on the keypad followed by *) The Nano will then transmit this token number and will be looking for a response from a bridge.

If more than one bridge replies, the Nano checks the signal strength and selects the strongest bridge to communicate with. The Net2 software confirms that this token number is in the database and if so registers this Net2 nano/bridge as a permanent binding.

In future, if this bridge connection should fail, the Nano will NOT automatically select another bridge. You must click Detect on the doors screen to call all the Nanos currently enrolled on the database. They will then establish new links with the available bridges and each one will bind with the strongest signal.

Net2 nano reset

The Nano controller holds the address information for the bridge that it has bound with. It will therefore never communicate with any other bridge. This can cause problems if the unit is to be used in another location.

The unit requires a hardware reset to clear its bridge address information. This is achieved by linking Orange/Mauve on the reader port and power cycle the unit.

Software Configuration

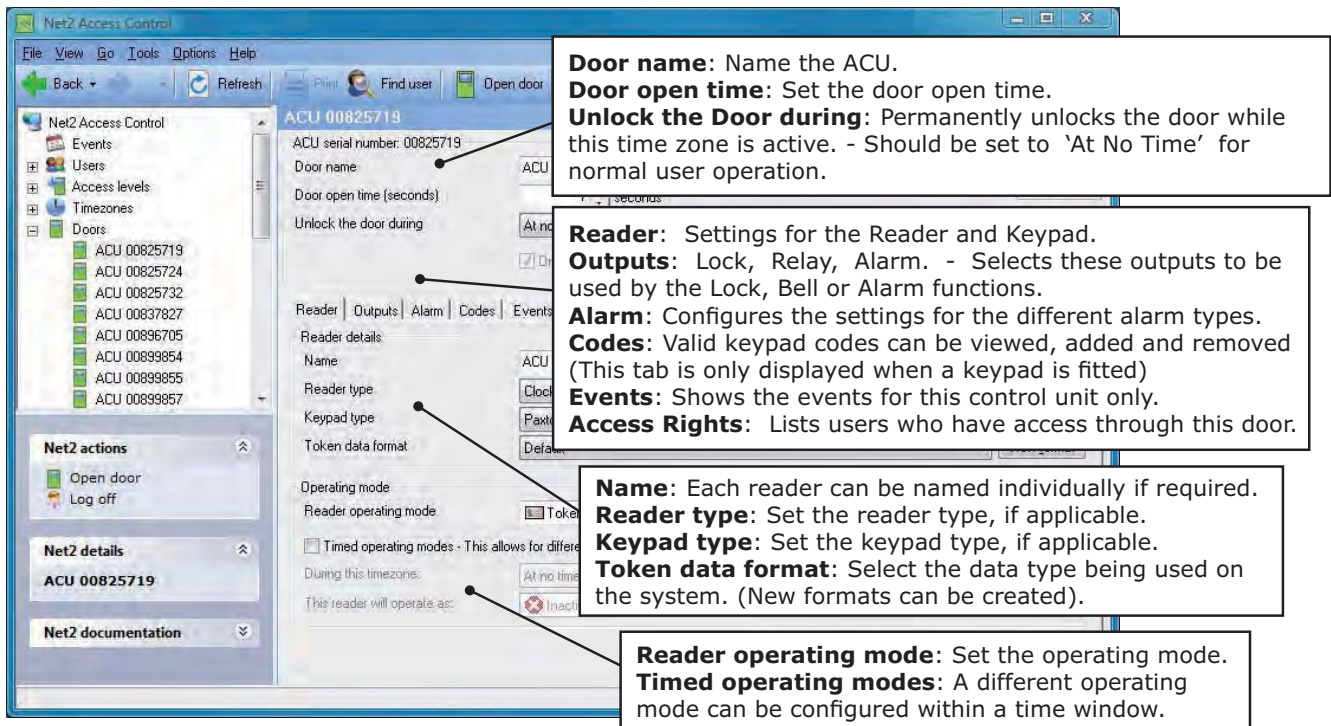

Door name: Name the ACU.
Door open time: Set the door open time.
Unlock the Door during: Permanently unlocks the door while this time zone is active. - Should be set to 'At No Time' for normal user operation.

Reader: Settings for the Reader and Keypad.
Outputs: Lock, Relay, Alarm. - Selects these outputs to be used by the Lock, Bell or Alarm functions.
Alarm: Configures the settings for the different alarm types.
Codes: Valid keypad codes can be viewed, added and removed (This tab is only displayed when a keypad is fitted)
Events: Shows the events for this control unit only.
Access Rights: Lists users who have access through this door.

Name: Each reader can be named individually if required.
Reader type: Set the reader type, if applicable.
Keypad type: Set the keypad type, if applicable.
Token data format: Select the data type being used on the system. (New formats can be created).

Reader operating mode: Set the operating mode.
Timed operating modes: A different operating mode can be configured within a time window.

This product is not suitable for retail sale. All warranties are invalid if this product is not installed by a competent person.



TransTech Systems
PO Box 2357 Wilsonville, OR 97070
Phone: 888.843.3643 Fax 503.682.0166
Email sales@ttsys.com www.ttsys.com

Here is the list of topics about this product that receive the most technical support enquiries.
We list them here to help you speed up the installation and trouble shooting process.

1 - ACU fails to enroll onto the PC (WIRELESS PROBLEMS).

The Net2 Nano must be in range of a Net2Air bridge. This can be checked with a Site Surveyor. Detailed advice can be found on the website as follows:-

- AN1095 - Net2 nano - How does it work? < <http://paxton.info/974> >*
- AN1096 - How to plan a Net2 nano installation < <http://paxton.info/975> >*
- Ins-30096 - Net2Air site surveyor < <http://paxton.info/1015> >*

2 - Readers/keypads not working.

- Software settings - Confirm that the settings of the reader or keypad are correct.
- Connections - Check the wiring and integrity of the connectors. If possible, test this reader on the other unit.
- Cable - Belden 9540 should be used to extend the reader cable (Max 100m). Twisted pair alarm cable should not be used. To confirm that an extended reader cable is not at fault, wire the reader direct into the reader port.
- Supply voltage - Confirm that the voltage is within specification. (see table)
- User token - Confirm that the user token used for testing is OK by presenting it to a known working reader.
- Interference - Confirm whether the reader works when tested 'in hand' and not mounted on the wall. Ensure that readers are not mounted back to back or there is no interference from other local RF devices.

3 - Why are some of the Net2 features (e.g. Fire alarm integration) not available on Net2 nano?

Wireless communication is not suitable for safety critical applications.

4 - Net2Air - What does this mean?

Net2Air is a term used to describe the wireless communication protocol used by Paxton Access products in much the same way as Bluetooth. The Net2Air protocol is not open, only Paxton Access products can use this technology.

The Net2Air protocol is based on the standard known as IEEE 802.15.4. It operates at 2.4GHz and can co-exist with wireless LAN networks and other devices using this frequency such as DECT phones. All Paxton Access products employ AES128 encryption technology to ensure that all communication remains secure.

Specifications			
Features	Min	Max	
Number of Cards	1	10,000	
Number of PINS	1	10,000	
Access Levels	1	250	
Time Zones	1	64	
Maximum door open time	1 sec	99,999 sec	
Number of Codes	1	50	
Doors per ACU	1	1	
Reader ports per ACU	1	1	
Readers per port	1	2	
Keypads per port	1	2	
ACU's per Net2Air bridge - Recommended	1	10	
Net2Air bridge (data lines) per system	1	50	
Net2Air wireless range to ACU		30 m	Typical 10 m
Data retention after total power loss		60 days	
Events stored in ACU with no server connection		4,096	
Electrical	Min	Max	
Voltage	11V DC	14.5V DC	
PCB Current (depending on activity)		120 mA	
Relay switchable voltage		24V DC	
Relay switchable current		2 A	
Dedicated lock output current		1.1 A	
Alarm output current		1 A	
Reader port output current		500 mA	
Carrier frequency			2.405 GHz
Environment	Min	Max	
Operating temperature - Battery limits	0 °C	+ 55 °C	
Waterproof			No
Dimensions	Width	Height	Depth
Control Unit	84 mm	106 mm	15 mm
Plastic Housing	170 mm	175 mm	40 mm



TransTech Systems
PO Box 2357 Wilsonville, OR 97070
Phone: 888.843.3643 Fax 503.682.0166
Email sales@ttsys.com www.ttsys.com

CE0889